



Operator's Manual Supplement

Special Supplement to Genie Operator's Manual

***For Authorized and Trained
Set Lighting Technicians and Studio Grips***

⚠ WARNING

This manual is solely for use by set lighting technicians and studio grips who have completed training offered by qualified trainers in aerial work platform operation combined with use of set lighting, camera equipment and light diffusion frames. Users of this manual must be trained as Genie aerial work platform operators. Failure to receive training and to use the information contained in this supplement and in the operator's manual may result in death or serious injury.

**Original Instructions
Second Edition
Second Printing
Part No. 1314078GT**

Introduction

Special Supplement to Genie Operator's Manual

**For Authorized and Trained Set Lighting
Technicians and Studio Grips**

Important

This is a supplemental manual and modifications permitted herein are exceptions to normal operation. Instructions for normal operation are contained in the Operator's Manual for each machine.

Genie reserves the right to modify this supplement without notice, or to revoke the modification approval if the supplement is used in a manner that creates a safety concern.

Manufacturer: CE & UKCA

Terex Global GmbH
Bleicheplatz 2
Schaffhausen, 8200
Switzerland

Note: Terex Global GmbH is also known as "Genie" when referenced in this manual.

EU Authorized representative:

Genie Industries B.V.
Boekerman 5
4751 XK OUD GASTEL
The Netherlands

UK Authorized representative:

Genie UK Limited
The Maltings
Wharf Road
Grantham
NG31 6BH
UK

Contents

Introduction	2
Important Information.....	3
Safety Rules.....	5
Wind Speed Chart.....	7
Platform Capacity Reduction	8
Platform Capacity Reduction Charts - Imperial ..	11
Platform Capacity Reduction Charts - Metric	14

Copyright © 1999 by Terex Corporation

Second Edition: Second Printing, June 2024

Genie is a registered trademark of Terex South Dakota, Inc. in the U.S.A. and many other countries.

These machines comply with

ANSI A92.20
CAN/CSA B354.6
AS 1418.10

 Complies with EC Directive 2006/42/EC
See EC Declaration of Conformity

 Supply of Machinery (Safety) Regulations 2008

Important Information



Warning

Failure to comply with the following requirements may result in death or serious injury.

- Any operator using Genie equipment in the manner set forth in this Supplemental Manual must be a Set Lighting Technician or Studio Grip and must have completed a specific training course that complies with the requirements of this Supplemental Manual. If you are not a Set Lighting Technician or Studio Grip who has received specific training, do not deviate from the requirements of the standard Genie Operator's Manual for use of Genie equipment.
- Strict compliance with this Supplemental Manual, as well as Genie's standard Operator's Manual and Manual of Responsibilities (ANSI markets), along with completion of specialized training, is essential to safe operation of the Approved Models as set forth in this supplement.

Approved Models

Model	From Serial Number:
Z [®] -34/22	Z34F-14001, Z34D-1900
Z [®] -45 XC™	Z4525XCM-1501
Z [®] -45 DC/FE	Z45EM-101
Z [®] -60 DC/FE	Z60H-3000, Z60M-1000
Z [®] -80/60	Z80H-7896 ANSI/CSA Z80H-7733 CE/UK
S [®] -45 XC™	S45XCH-101
S [®] -45 TRAX™	S45XCH-101
S [®] -65 XC™	S60XCH-45001, S65XCM-101
S [®] -65 TRAX™	S60XCH-45001, S65XCM-101
S [®] -60 J	S60JH-101, S60JD-101
S [®] -80 J	S80JH-101, S80JD-101
S [®] -60 DC/FE	S60EM-101
S [®] -85 XC™	S80XCH-101
SX™-125 XC™	SX125D-101



Important Information

Limited Purpose of This Manual

This Supplemental Manual was prepared by Genie at the express request of unions representing Set Lighting Technicians and Studio Grips. These operators requested Genie's written permission to use the Approved Models listed in certain ways that deviate from Genie's standard manuals for that equipment. This Supplemental Manual contains Genie's written permission and the requirements that must be followed by specifically trained operators to enable them to use the Approved Models in the manner set forth in this Supplemental Manual.

Proof of Training and Records Retention

Qualified trainers shall provide proof of training to all successful trainees. The document evidencing training shall include the following information:

- The name of the person (operator) being trained or retrained.
- The name of the organization providing training or retraining.
- The name of the trainer(s).
- Clear identification that the training covered the applications contained in this Supplemental Manual.
- The date of training.

Records of training shall be retained by the trainers for at least four years and shall include all the information listed above.

Safety Rules



Danger

Failure to comply with the following requirements will result in death or serious injury.

Modification of the Approved Models for use by attachment of lights, light mounting hardware, camera mounting hardware and light diffusion frames (LDFs) to the platform guard rail is authorized by Genie only if the following rules and requirements are strictly followed:

- Operators must have completed training for the attachment of lighting or camera equipment and LDFs to the platform guard rail. Training must include, but not be limited to, information regarding the effect on platform capacity and stability resulting from the attachment of equipment to the platform guard rail or to the boom of the aerial lift, and hazards associated with this application.
- All operating instructions and warnings contained in the Operator's Manual, Safety Manual (ANSI markets) and Manual of Responsibilities (ANSI markets), and on decals found on the particular Genie aerial lift, must be followed.
- The aerial lift must be operated only on a firm, level surface.
- Operators must be trained and be able to demonstrate proficiency in the operation of the specific model of Genie aerial lift being operated.
- Genie booms are not insulated. Precautions shall be taken to protect the operator and people on the ground from electrocution hazards. The attachment of power supply cables to the boom shall not restrict the movement of the aerial lift or endanger the operator or people on the ground.
- Attachment of power supply cables to the boom shall be accomplished in a manner that does not cause a tip-over hazard due to a side or vertical force that could result in the machine becoming unstable.
- Power supply cables must be attached to the end of each boom section in a manner that ensures the cable cannot be damaged from tensioning, pinching or crushing when the boom is operated.

Safety Rules

- LDFs hung from the platform guard rail must not be rigidly attached in any manner that could cause or impose a side or vertical load from wind or contact with adjacent objects greater than the rated side load posted at the entrance to the platform.
- Attachment of LDFs and rope to the platform shall be accomplished in a manner that does not cause a tip-over hazard due to a side or vertical force that could result in the machine becoming unstable.
- Do not alter the guard rail system by drilling, welding, crushing, damaging or making any other modifications that compromise the strength of the guard rail when attaching movie production equipment.
- The entrance to the platform, the platform controls, including the foot switch and the emergency stop button, the lanyard anchorage points, the platform decals and instruction container must remain accessible when movie production equipment is attached to the platform.
- Operators must not gain access to or exit the platform by means of walking or climbing on the boom or lift structure or by attaching a rope or a hanging ladder from the platform or its supporting structure. Access to and exit from the platform shall be accomplished at ground level only.
- The combined weight of platform attachments, power supply cables, mounting hardware, platform occupant(s), tools and equipment must in all cases remain less than the maximum rated platform capacity for both personnel lifting and material only lifting applications. Use the platform capacity reduction chart found in this supplement to determine allowable platform load.
- The number and size of attachments must be limited by consideration of the maximum allowable wind speed and the surface area of platform attachments. Use the wind speed chart found in this supplement to determine maximum allowable wind speed.
- Information regarding the attachment of LDFs and lighting and camera equipment shall be supplied only to trained union members. Operators must be familiar with these supplemental instructions and warnings before they are allowed to operate any Genie boom that is approved for this application.
- The grips panel must be mounted in a way that the center of gravity of the frame is always located below the platform floor.
- An accurate wind speed measuring device, such as an anemometer, must be used to measure the wind speed if the wind speed charts are to be used.

Wind Speed Chart

For Light Diffusion Frames and Large Surface Area Platform Attachments on Genie Booms



Tip Over Hazard

Using a boom in wind speeds greater than recommended or exceeding the recommended surface area of the platform by attaching movie production equipment will result in the boom becoming unstable and will result in death or serious injury.

Frame Size m	Area sq.m	Maximum Wind Speed m/s
1.2 x 1.2	1.5	12.5
1.8 x 1.8	3.3	12.5
2.4 x 2.4	5.9	9.8
3.7 x 3.7	13.4	6.5
6.1 x 6.1	37.2	4

When movie production equipment, such as light diffusion frames or set lighting, is attached to a boom platform, operation in windy conditions is limited by the frame size (or total surface area of the equipment) and wind speed as follows:

- Machines used outside with a device to accurately measure the wind can use the full wind speed table.
- Machines used outside without a device to accurately measure the wind must assume 28 mph/12.5 ms when using the table.
- Machines that are used indoors can assume 0 mph wind and therefore use the largest diffusion frame listed.

Frame Size ft	Area sq ft	Maximum Wind Speed mph
4 x 4	16	28
6 x 6	36	28
8 x 8	64	22
12 x 12	144	14.5
20 x 20	400	9



Platform Capacity Reduction

For Determining the Reduction In Platform Capacity Due To Attachment Of Movie Production Equipment To Genie Boom Platforms

▲ DANGER Tip Over Hazard

Exceeding the recommended load restrictions of the platform by attaching movie production equipment will result in the boom becoming unstable and will result in death or serious injury. Always calculate the reduction of the platform capacity caused by attachment of more production equipment.

Theory:

Platform maximum capacity is based on an evenly distributed load. When movie production equipment, such as light diffusion frames, set lighting and camera mounts, are attached to the front of the platform (entry side), the platform capacity is reduced by more than the weight of the equipment. The farther the equipment is mounted from the center of the platform, the greater the reduction in platform capacity.

Definition:

Center of Gravity (C.G.): The balance point of an object. The point at which the entire weight of an object is concentrated so that if the object is suspended from that point, it will be balanced.

Reduce platform capacity according to the following:

- Attachment of power supply cables to the boom reduces the platform capacity. Subtract the total suspended weight of cables and rigging from the rated platform capacity.
- Subtract the load applied to the platform by the attachment of additional movie production equipment (as shown in Illustration 1) by using the procedure and the Platform Capacity Reduction Chart.
- No additional load above rated platform capacity is allowed. Personnel and payload (with adjustment per Platform Capacity Reduction Chart) must not exceed the load shown in the appropriate Operator's Manual and Decals for your machine.

How to use this chart

Follow these steps for each piece of equipment attached to the platform.

- 1 Locate the weight of your equipment in the first column on the chart. Always round up to the next number.

Platform Capacity Reduction

- 2 Measure the distance from the back toeboard to the center of gravity of the equipment (distance A or distance B). This is the load center. Refer to Illustration 1.

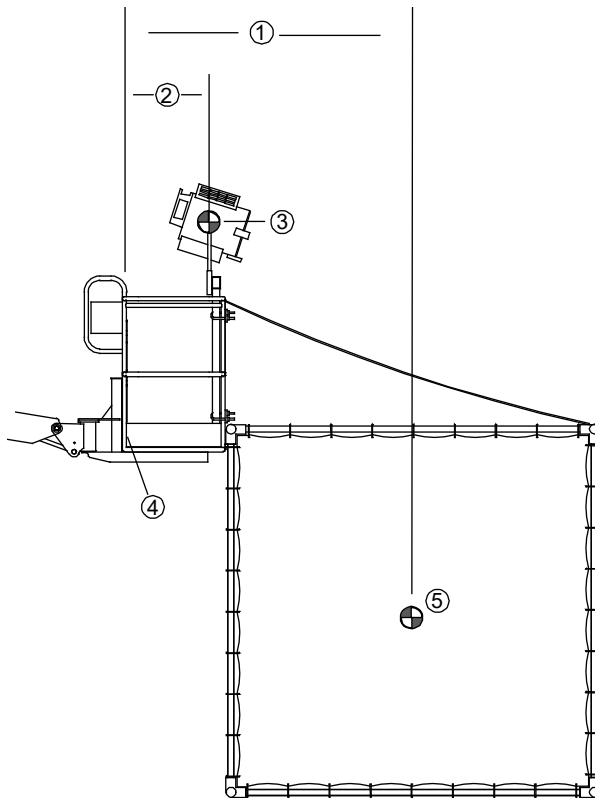
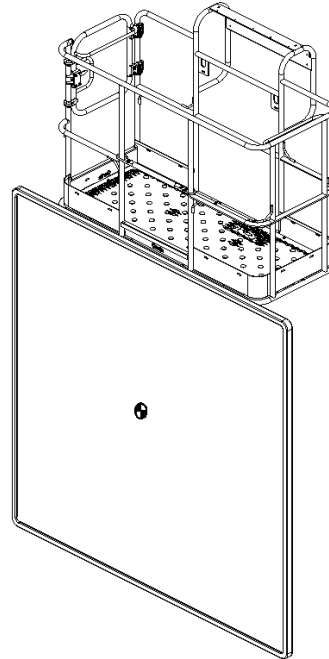

Illustration 1

- 1 Distance (B)
- 2 Distance (A)
- 3 Center of gravity of light and mounting bracket
- 4 Back of toeboard
- 5 Center of gravity of diffusion frame



- 1 From these numbers, determine the total load of your equipment on the platform.

Personnel lifting applications: Subtract this number from the maximum platform capacity of the machine, as defined in the appropriate machine operator's manual and decals, to determine the remaining platform capacity.

Example: Lighting equipment and the mounting bracket used to attach it to the guard rail weigh 167 lbs/76 kgs. Their center of gravity (balance point) is located at 35 in/0.8 m from the back toeboard. Because the load is concentrated at the front guard rail, its effect on capacity is greater than a distributed load. The chart tells us that the reduction in capacity is 234 lbs/106 kgs. On a platform with a 500 lbs/227 kgs capacity, the remaining capacity is 266 lbs (500-234=266) or 121 kgs (227-106=121).

Platform Capacity Reduction

Platform Capacity Chart

Use this chart to determine the correct Platform Capacity Reduction Chart for your machine.

For models with unrestricted and restricted platform capacities, refer to the Range of Motion Charts in the Operators Manual on your machine.

Model	Reduction chart			
	Unrestricted Capacity Rating		Restricted Capacity Rating	
	lbs	kgs	lbs	kgs
Z [®] -34/22	500	227		
Z [®] -45 XC [™]	660	300		
Z [®] -45 DC/FE	660	300		
Z [®] -60 DC/FE	500	227		
Z [®] -80/60	500	227		
S [®] -45 XC [™]	660	300	1000	454
S [®] -45 TRAX [™]	660	300	1000	454
S [®] -65 XC [™]	660	300	1000	454
S [®] -65 TRAX [™]	660	300	1000	454
S [®] -60 J	660	300		
S [®] -80 J	660	300		
S [®] -60 DC/FE	660	300		
S [®] -85 XC [™]	660	300	1000	454
SX [™] -125 XC [™]	660	300	1000	454

Platform Capacity Reduction Charts - Imperial

Platform Capacity Reduction Chart - 500 lbs Platform Rating

		Load Center From Back Of Platform Toeboard To Center Of Gravity (Inches)												
		23.56	30	36	48	60	72	84	96	108	120	132	144	156
Total Weight of Equipment (lbs)	50	50	59	67	83	99	116	132	148	164	181	197	213	229
	75	75	88	100	125	149	173	198	222	246	271	295	320	344
	100	100	117	134	166	199	231	264	296	329	361	394	426	459
	125	125	147	167	208	248	289	330	370	411	451	492		
	150	150	176	201	249	298	347	395	444	493				
	175	175	206	234	291	348	404	461						
	200	200	235	267	332	397	462							
	225	225	264	301	374	447								
	250	250	294	334	415	497								
	275	275	323	368	457									
	300	300	352	401	498									
	325	325	382	434										
	350	350	411	468										
	375	375	440											
	400	400	470											
425	425	499												
450	450													
475	475													
500	500													



Platform Capacity Reduction Charts - Imperial

Platform Capacity Reduction Chart - 660 lbs Platform Rating

		Load Center From Back Of Platform Toeboard To Center Of Gravity (Inches)												
		24	30	36	48	60	72	84	96	108	120	132	144	156
Total Weight of Equipment (lbs)	50	50	59	67	83	99	116	132	148	164	181	197	213	229
	75	75	88	100	125	149	173	198	222	246	271	295	320	344
	100	100	117	134	166	199	231	264	296	329	361	394	426	459
	125	125	147	167	208	248	289	330	370	411	451	492	533	573
	150	150	176	201	249	298	347	395	444	493	542	590	639	
	175	175	206	234	291	348	404	461	518	575	632			
	200	200	235	267	332	397	462	527	592	657				
	225	225	264	301	374	447	520	593						
	250	250	294	334	415	497	578	659						
	275	275	323	368	457	546	636							
	300	300	352	401	498	596								
	325	325	382	434	540	646								
	350	350	411	468	582									
	375	375	440	501	623									
	400	400	470	535										
	425	425	499	568										
450	450	528	602											
475	475	558	635											
500	500	587												
525	525	617												
550	550	646												
575	575													
600	600													
625	625													
650	650													



Platform Capacity Reduction Charts - Imperial

Platform Capacity Reduction Chart - 1000 lbs Platform Rating

Load Center From Back Of Platform Toeboard To Center Of Gravity (Inches)

		24	30	36	48	60	72	84	96	108	120	132	144	156
Total Weight of Equipment (lbs)	50	50	59	67	83	99	116	132	148	164	181	197	213	229
	75	75	88	100	125	149	173	198	222	246	271	295	320	344
	100	100	117	134	166	199	231	264	296	329	361	394	426	459
	125	125	147	167	208	248	289	330	370	411	451	492	533	573
	150	150	176	201	249	298	347	395	444	493	542	590	639	688
	175	175	206	234	291	348	404	461	518	575	632	689	746	802
	200	200	235	267	332	397	462	527	592	657	722	787	852	917
	225	225	264	301	374	447	520	593	666	739	812	886	959	
	250	250	294	334	415	497	578	659	740	821	903	984		
	275	275	323	368	457	546	636	725	814	904	993			
	300	300	352	401	498	596	693	791	888	986				
	325	325	382	434	540	646	751	857	962					
	350	350	411	468	582	695	809	923						
	375	375	440	501	623	745	867	989						
	400	400	470	535	665	795	925							
	425	425	499	568	706	844	982							
	450	450	528	602	748	894								
	475	475	558	635	789	944								
	500	500	587	668	831	993								
	525	525	617	702	872									
550	550	646	735	914										
575	575	675	769	955										
600	600	705	802	997										
625	625	734	835											
650	650	763	869											
675	675	793	902											
700	700	822	936											
725	725	851	969											
750	750	881												
775	775	910												
800	800	939												
825	825	969												
850	850	998												
875	875													
900	900													
925	925													
950	950													
975	975													
1000	1000													



Platform Capacity Reduction Charts - Metric

Platform Capacity Reduction Chart - 227 kg Platform Rating

		Load Center From Back Of Platform Toeboard To Center Of Gravity (Meter)													
		0.6	0.8	0.9	1.2	1.5	1.8	2.1	2.4	2.7	3.0	3.4	3.7	4.0	
Total Weight of Equipment (kg)	Platform Capacity Reduction (kg)	23	23	27	30	38	45	52	60	67	75	82	89	97	104
		34	34	40	45	57	68	79	90	101	112	123	134	145	156
		45	45	53	61	75	90	105	120	134	149	164	179	193	208
		57	57	67	76	94	113	131	149	168	186	205	223		
		68	68	80	91	113	135	157	179	201	224				
		79	79	93	106	132	158	183	209						
		91	91	107	121	151	180	210							
		102	102	120	136	170	203								
		113	113	133	152	188	225								
		125	125	146	167	207									
		136	136	160	182	226									
		147	147	173	197										
		159	159	186	212										
		170	170	200											
181	181	213													
193	193	226													
204	204														
215	215														
227	227														



Platform Capacity Reduction Charts - Metric

Platform Capacity Reduction Chart - 300 kg Platform Rating

LOAD CENTER FROM BACK OF TOEBOARD TO CENTER OF GRAVITY (Meter)

		0.6	0.8	0.9	1.2	1.5	1.8	2.1	2.4	2.7	3.0	3.4	3.7	4.0
Total WEIGHT OF EQUIPMENT (kg)	23	23	27	30	38	45	52	60	67	75	82	89	97	104
	34	34	40	45	57	68	79	90	101	112	123	134	145	156
	45	45	53	61	75	90	105	120	134	149	164	179	193	208
	57	57	67	76	94	113	131	149	168	186	205	223	242	260
	68	68	80	91	113	135	157	179	201	224	246	268	290	
	79	79	93	106	132	158	183	209	235	261	287			
	91	91	107	121	151	180	210	239	269	298				
	102	102	120	136	170	203	236	269						
	113	113	133	152	188	225	262	299						
	125	125	146	167	207	248	288							
	136	136	160	182	226	270								
	147	147	173	197	245	293								
	159	159	186	212	264									
	170	170	200	227	283									
181	181	213	243											
193	193	226	258											
204	204	240	273											
215	215	253	288											
227	227	266												
238	238	280												
249	249	293												
261	261													
272	272													
283	284													
295	295													



Platform Capacity Reduction Charts - Metric

Platform Capacity Reduction Chart - 454 kg Platform Rating

LOAD CENTER FROM BACK OF TOEBOARD TO CENTER OF GRAVITY (Meter)

		0.6	0.8	0.9	1.2	1.5	1.8	2.1	2.4	2.7	3.0	3.4	3.7	4.0
WEIGHT OF EQUIPMENT (kg)	23	23	27	30	38	45	52	60	67	75	82	89	97	104
	34	34	40	45	57	68	79	90	101	112	123	134	145	156
	45	45	53	61	75	90	105	120	134	149	164	179	193	208
	57	57	67	76	94	113	131	149	168	186	205	223	242	260
	68	68	80	91	113	135	157	179	201	224	246	268	290	312
	79	79	93	106	132	158	183	209	235	261	287	312	338	364
	91	91	107	121	151	180	210	239	269	298	328	357	386	416
	102	102	120	136	170	203	236	269	302	335	369	402	435	
	113	113	133	152	188	225	262	299	336	373	409	446		
	125	125	146	167	207	248	288	329	369	410	450			
	136	136	160	182	226	270	315	359	403	447				
	147	147	173	197	245	293	341	389	437					
	159	159	186	212	264	315	367	419						
	170	170	200	227	283	338	393	448						
	181	181	213	243	301	360	419							
	193	193	226	258	320	383	446							
	204	204	240	273	339	405								
	215	215	253	288	358	428								
	227	227	266	303	377	451								
	238	238	280	318	396									
	249	249	293	333	415									
	261	261	306	349	433									
	272	272	320	364	452									
283	283	333	379											
295	295	346	394											
306	306	360	409											
318	318	373	424											
329	329	386	440											
340	340	400												
352	352	413												
363	363	426												
374	374	439												
386	386	453												
397	397													
408	408													
420	420													
431	431													
442	442													
454	454													



California Proposition 65



Operating, servicing and maintaining this equipment can expose you to chemicals including engine exhaust, carbon monoxide, phthalates, and lead, which are known to the State of California to cause cancer and birth defects or other reproductive harm. These chemicals can be emitted from or contained in other various parts and systems, fluids and some component wear by-products. To minimize exposure, avoid breathing exhaust, do not idle the engine except as necessary, service your equipment and vehicle in a well-ventilated area and wear gloves or wash your hands frequently when servicing your equipment or vehicle and after operation. For more information go to www.P65Warnings.ca.gov/passenger-vehicle.

Breathing diesel engine exhaust exposes you to chemicals known to the State of California to cause cancer and birth defects or other reproductive harm.

- Always start and operate the engine in a well-ventilated area.
- If in an enclosed area, vent the exhaust to the outside.
- Do not modify or tamper with the exhaust system.
- Do not idle the engine except as necessary.

For more information go to www.P65warnings.ca.gov/diesel.